

PAD RETAINER - ZUGBOLZENSATZ - GRUPPO TIRANTE

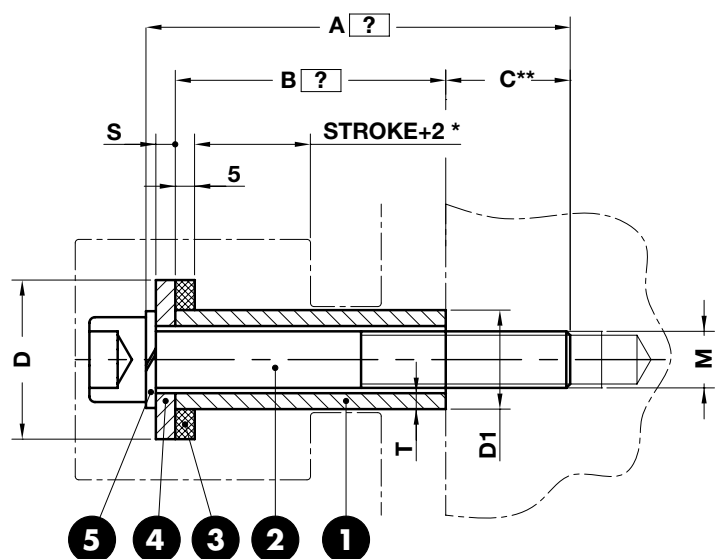

Respect the max. load
Maximale Nutzlast beachten
Rispettare il carico max.

Notes

- 1 Material:** St37
- 2** DIN 912 cl. 8.8
- 3 Material:** Elastomer 92SH
- 4 Material:** CK45
- 5** DIN 127



Art.	M=M10	A=100	B=76
C13.25.	M10	A100	B076

* Hub +2, Corsa +2

** 1,5 x d on steel, auf stahl, su acciaio
2 x d on cast iron, auf gusseisen, su ghisa

OMCR CODE	D	D1	M	S	T	Max load (kN)
C13.25.	32	16	M10	4	2,5	1
C13.25.	36	20	M12	6	3,5	1,5
C13.25.	45	28	M16	6	5,5	2,5

PAD RETAINER - ZUGBOLZENSATZ - GRUPPO TIRANTE

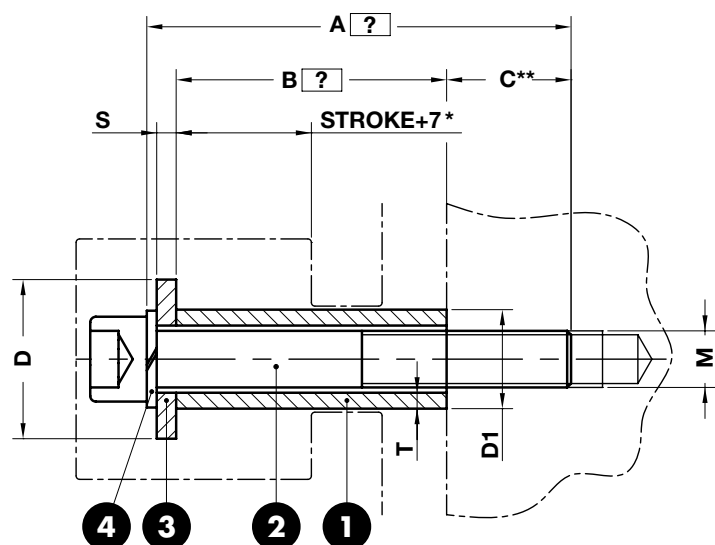

Respect the max. load
Maximale Nutzlast beachten
Rispettare il carico max.

Notes

- 1 Material:** St37
- 2** DIN 912 cl. 8.8
- 3 Material:** CK45
- 4** DIN 127



Art.	M=M10	A=100	B=76
C13.26.	M10	A100	B076

* Hub +7, Corsa +7

** 1,5 x d on steel, auf stahl, su acciaio
2 x d on cast iron, auf gusseisen, su ghisa

OMCR CODE	D	D1	M	S	T	Max load (kN)
C13.26.	25	16	M10	4	2,5	1
C13.26.	30	20	M12	6	3,5	1,5
C13.26.	40	28	M16	6	5,5	2,5