

hard material matters



**MSS - Monobloc holders for parting and grooving**





# The system

# MSS

the modular parting, grooving and threading system

– complemented by monobloc tool holders –



Monobloc tool holder, system GX, for inserts with two cutting edges, size GX24.  
Inexpensive solution for **radial grooving**, **parting** up to  $\varnothing 42$  mm and **turning operations**.

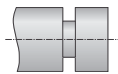

Grooving

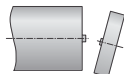

Parting

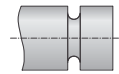

Profile  
grooving

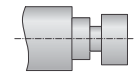

Grooving  
and turning

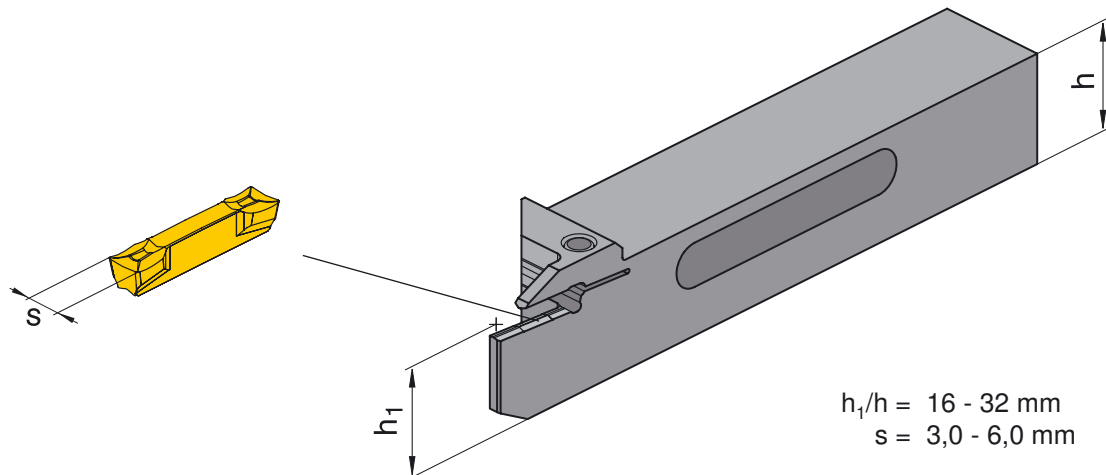

$h_1/h = 16 - 32$  mm  
 $s = 3,0 - 6,0$  mm

## System characteristics

- Monobloc version
- Active insert clamping
- Double-blade insert
- Ground and directly pressed insert

## Benefits

- Application safety, **easy handling**, only **one spare part**
- Well-suited for copy turning
- High profitability
- Optimum solution for all situations

# The width classes ( System GX )

# MSS

the modular parting, grooving and threading system

– complemented by monobloc tool holders –



Width class	-1	-2	-3	-4	-5
Tools					
Parting and grooving inserts					

Tool description:

E25R0021-2525M-GX24-2

Insert description:

GX24-2E3.00N0.30-F2

Width class 1)

The parting and grooving widths of the MSS system are divided into width classes. Every width class represents a certain range of parting and grooving widths. The adequate tool can be assigned to the elected grooving width by means of the width class.

1) Ideally the module and the insert have the same width class. This combination results in the best possible application safety.

# System description

# MSS

the modular parting, grooving and threading system

– complemented by monobloc tool holders –



## Monobloc tool holder designations



E = external / I = internal	Assembly size	Version	Approach angle	Max. cutting depth	Shank cross section	Shank length	Insert system	Insert size	Width class
E	25	R	00	21	- 2525	M	- GX	24	- 2

## Insert designations

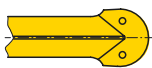



Insert system	Insert size	Width class	Insert shape / application	Cutting width / pitch	Version / thread standard	Corner radius / angle	Chip groove code
GX	24	- 2	E	3.00	N	0.30	- Code
GX	24	- 3	R	2.50	N		- Code



# Tools

## Monobloc holder GX24 system

<b>Application</b>								
--------------------	---	---	--	--	--	--	--	--

### Right-hand GX monobloc holder



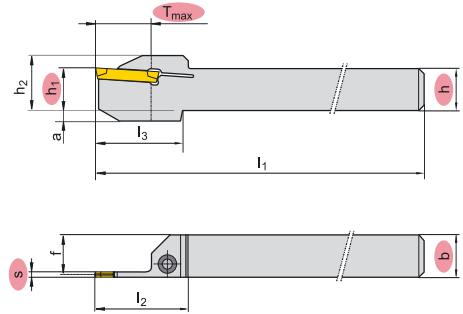

Picture shows right-hand version



h=h <sub>1</sub>	b	s	T <sub>max</sub>	Type, description	[mm]						Grooving inserts	Page
					f	h <sub>2</sub>	l <sub>1</sub>	l <sub>2</sub>	l <sub>3</sub>	a		
16	16	2,76 - 3,75	21	E16R0021-1616K-GX24-2	15,00	21	125	35	32	4	GX24-2...	8 + 9
20	20	2,76 - 3,75		E20R0021-2020K-GX24-2	19,00	25	125	35	-	-	GX24-2...	
		3,76 - 5,00		E20R0021-2020K-GX24-3	18,53						GX24-3...	
25	25	2,76 - 3,75		E25R0021-2525M-GX24-2	24,00	30	150	35	-	-	GX24-2...	
		3,76 - 5,00		E25R0021-2525M-GX24-3	23,53						GX24-3...	
		5,01 - 6,50		E25R0021-2525M-GX24-4	22,90						GX24-4...	
32	25	2,76 - 3,75		E32R0021-3225P-GX24-2	24,00	37	170	35	-	-	GX24-2...	
		3,76 - 5,00		E32R0021-3225P-GX24-3	23,53						GX24-3...	
		5,01 - 6,50		E32R0021-3225P-GX24-4	22,90						GX24-4...	

**Ordering example:** 1 piece E32R0021-3225P-GX24-3

Spare parts and accessories	 Clamping screw	 T-key
E16R0021-1616K-GX24-2	7897218 (M4,0 x 18 - T20)	7897207 (T20)
E20R0021-2020K-GX24-2		
E20R0021-2020K-GX24-3		
E25R0021-2525M-GX24-2		
E25R0021-2525M-GX24-3		
E25R0021-2525M-GX24-4		
E32R0021-3225P-GX24-2		
E32R0021-3225P-GX24-3		
E32R0021-3225P-GX24-4		

<b>Tools / modules</b>								
see page								

# Tools

## Monobloc holder GX24 system

<b>Application</b>								
--------------------	---	---	--	--	--	--	--	--

### Left-hand GX monobloc holder



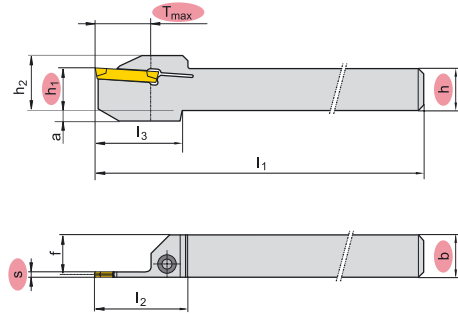

Picture shows right-hand version



h=h <sub>1</sub>	b	s	T <sub>max</sub>	Type, description	[mm]					Grooving inserts	Page	
					f	h <sub>2</sub>	l <sub>1</sub>	l <sub>2</sub>	l <sub>3</sub>			a
16	16	2,76 - 3,75	21	E16L0021-1616K-GX24-2	15,00	21	125	35	32	4	GX24-2...	8 + 9
20	20	2,76 - 3,75		E20L0021-2020K-GX24-2	19,00	25	125	35	-	-	GX24-2...	
		3,76 - 5,00		E20L0021-2020K-GX24-3	18,53						GX24-3...	
25	25	2,76 - 3,75		E25L0021-2525M-GX24-2	24,00	30	150	35	-	-	GX24-2...	
		3,76 - 5,00		E25L0021-2525M-GX24-3	23,53						GX24-3...	
		5,01 - 6,50		E25L0021-2525M-GX24-4	22,90						GX24-4...	
32	25	2,76 - 3,75		E32L0021-3225P-GX24-2	24,00	37	170	35	-	-	GX24-2...	
		3,76 - 5,00		E32L0021-3225P-GX24-3	23,53						GX24-3...	
		5,01 - 6,50		E32L0021-3225P-GX24-4	22,90						GX24-4...	

**Ordering example:** 1 piece E32L0021-2525M-GX24-4

Spare parts and accessories	 Clamping screw	 T-key
E16L0021-1616K-GX24-2	7897218 (M4,0 x 18 - T20)	7897207 (T20)
E20L0021-2020K-GX24-2		
E20L0021-2020K-GX24-3		
E25L0021-2525M-GX24-2		
E25L0021-2525M-GX24-3		
E25L0021-2525M-GX24-4		
E32L0021-3225P-GX24-2		
E32L0021-3225P-GX24-3		
E32L0021-3225P-GX24-4		

<b>Tools / modules</b>								
see page								

# Inserts GX24 system

Application								
-------------	--	--	--	--	--	--	--	--

Cutting width 3,00 - 6,00 mm



standard



-F2



-27P

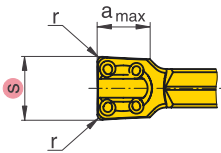
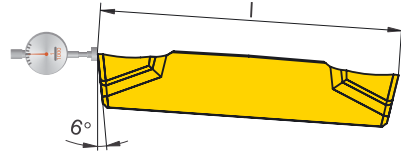

= repeatability see below

s	Type, Bestellbezeichnung	l	[mm]		Hardness							Toughness	
			r	a <sub>max</sub>	AMZ	H216T	TSM20	SR127	GM127	SR735	GM40	GM740	
3,00	GX24-2E3.00N0.30	24	0,30	2,5				●			●		
	GX24-2E3.00N0.30-F2		0,30	2,5				●		●		●	
	GX24-2E3.00N0.30-27P		0,30	2,5	●								
3,50	GX24-2E3.50N0.30-F2		0,30	2,5				●		●		●	
	GX24-3E4.00N0.40		0,40	3,0				●			●		
4,00	GX24-3E4.00N0.40-F2		0,40	3,0				●		●		●	
	GX24-3E4.00N0.40-27P		0,40	3,0	●								
4,50	GX24-3E4.50N0.40-F2		0,40	3,0				●		●		●	
5,00	GX24-3E5.00N0.40		0,40	3,0				●			●		
	GX24-3E5.00N0.40-F2		0,40	3,5				●		●		●	
	GX24-3E5.00N0.40-27P		0,40	3,5	●								
6,00	GX24-4E6.00N0.50		0,50	3,5				●			●		
	GX24-4E6.00N0.50-F2	0,50	4,0				●		●		●		
	GX24-4E6.00N0.50-27P	0,50	4,0	●									
Tolerances [mm]						Steel	○	●	●	●	●	●	●
	x	s	r				Stainless	○	●	○	○	○	●
GX24-.E...	± 0,18	± 0,05	± 0,05				Cast iron	○	○	●	●	●	●
-F2 / -27P	± 0,02	± 0,02	± 0,05				Non ferrous metals	●	●	●	●	●	●



You can find application recommendations on pages 10 - 15!

Tools / modules	GX24	GX24 axial	GX24	GX24	See page "D29", catalogue no. 148 "MSS - The modular parting, grooving and threading system"
see page	D16	D17-20	D42	D29	



# Inserts

## GX24 system - radius inserts

Application							
-------------	---	---	---	--	--	--	--

**Cutting width 3,00 - 8,00 mm**



**-M3**



**-27P**

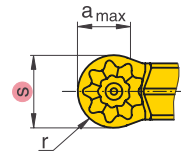
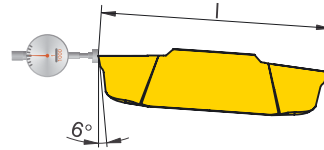

= repeatability see below

s	Type, Bestellbezeichnung	[mm]			Hardness							Toughness		
		l	r	a <sub>max</sub>	AMZ	H216T	TSM20	SR127	GM127	SR735	GM40	GM740		
3,00	GX24-2R1.50N-M3	24	1,50	1,5					●	●				
4,00	GX24-3R2.00N-M3		2,00	2,5					●	●				
5,00	GX24-3R2.50N-M3		2,50	3,0					●	●				
6,00	GX24-4R3.00N-M3		3,00	3,5					●	●				
6,00	GX24-4R3.00N-27P	25,37	3,00	4,0			●							

	x	s	r
-27P	± 0,02	± 0,02	± 0,05
-M3	± 0,18	± 0,05	± 0,05

	Steel	○	●	●	●	●	●	●	●
	Stainless	○	○	○	○	○	○	○	○
	Cast iron	○	○	○	○	○	○	○	○
	Non ferrous metals	○	○	○	○	○	○	○	○

● = International CERATIZIT range, for present availability see price list

**Ordering example:** 30 pieces GX24-4R3.00N-27P TSM20

**You can find application recommendations on pages 10 - 15!**

Tools / modules	GX24	GX24 axial	GX24	GX24	
see page	 D16	 D17-20	 D42	 D29	<p>See page "D29", catalogue no. 148 "MSS - The modular parting, grooving and threading system"</p> 

# Cutting data values

Workpiece material		Type of treatment / alloy	VDI 3323 group	Hardness HB	
A	Non alloyed steel	annealed	≤ 0,15% C	1	125
		annealed	0,15% - 0,45% C	2	150 - 250
		tempered	≥ 0,45% C	3	300
	Low alloyed steel	annealed		6	180
		tempered		7 / 8	250 - 300
		tempered		9	350
	High alloyed steel	annealed		10	200
		tempered		11	350
	Corrosion resistant steel	annealed	ferritic	12	200
		tempered	martensitic	13	325
R	Stainless steel	annealed	ferritic / martensitic	14	200
		quenched	austenitic	14	180
		quenched	duplex	14	230 - 260
		hardened	martensitic / austenitic	14	330
F	Grey cast iron		perlitic / ferritic	15	180
			perlitic / martensitic	16	260
	Grey cast iron with spheroidal graphite		ferritic	17	160
			perlitic	18	-
	Tempered iron		ferritic	19	130
			perlitic	20	230
N	Aluminium wrought alloys	non hardened		21	60
		hardened		22	100
	Aluminium cast alloys	non hardened	< 12% Si	23	80
		hardened	< 12% Si	24	90
		non hardened	> 12% Si	25	130
	Copper and copper alloys (bronze, brass)		machining alloy stock (1% Pb)	26	-
			brass, red bronze	27	-
			bronze	28	90
			lead-free copper and electrolytic copper	29	100
	Non metal materials		thermosetting plastics	29	100
		fibre-reinforced plastics	29	-	
		hard rubber	30	-	
S	Heat resistant alloys	annealed	Fe-base	31	200
		hardened	Fe-Fe-base	32	280
		annealed	Ni- or Co-base	33	250
		hardened	Ni- or Co-base 30 - 58 HRC	34	-
		cast	Ni- oder Co-base 1500 - 2200 Nmm <sup>2</sup>	35	-
	Titanium alloys		pure titanium	36	R <sub>m</sub> 440*
		alpha + beta alloys	37	R <sub>m</sub> 1050*	
H	Tempered steel	hardened and tempered		38	55 HRC
		hardened and tempered		39	60 HRC
	Chilled castings	cast		40	400
	Tempered cast iron	hardened and tempered		40	55 HRC

\* R<sub>m</sub> = maximum strength, measured in MPa

# Cutting data values

SR127	SR735	GM40	GM740	H216T	TSM20
$v_c$ [m/min]	$v_c$ [m/min]	$v_c$ [m/min]	$v_c$ [m/min]	$v_c$ [m/min]	$v_c$ [m/min]
150 - 280	130 - 220	130 - 220	110 - 150	—	—
130 - 240	110 - 140	110 - 140	80 - 120	—	—
100 - 200	70 - 150	70 - 150	70 - 110	—	—
140 - 220	120 - 190	120 - 190	70 - 100	—	—
130 - 180	110 - 150	110 - 150	70 - 90	—	—
100 - 160	70 - 130	70 - 130	60 - 90	—	—
120 - 170	90 - 140	90 - 140	60 - 80	—	—
100 - 150	70 - 130	70 - 130	60 - 80	—	—
60 - 100	120 - 200	120 - 200	90 - 130	—	—
140 - 220	60 - 80	60 - 80	60 - 80	—	—
120 - 200	—	120 - 200	100 - 180	—	—
80 - 130	—	100 - 170	80 - 150	—	—
60 - 100	—	70 - 110	70 - 110	—	—
120 - 200	—	60 - 90	60 - 90	—	—
100 - 160	—	—	—	110 - 180	100 - 180
130 - 200	—	—	—	90 - 150	90 - 150
100 - 160	—	—	—	110 - 180	100 - 170
120 - 230	—	—	—	80 - 140	70 - 130
90 - 180	—	—	—	100 - 200	90 - 180
—	—	—	—	70 - 160	70 - 150
—	—	—	—	100 - 800	100 - 800
—	—	—	—	80 - 800	80 - 800
—	—	—	—	80 - 500	80 - 800
—	—	—	—	—	—
—	—	—	—	—	—
—	—	—	—	80 - 300	80 - 300
—	—	—	—	200 - 600	150 - 600
—	—	—	—	150 - 400	100 - 300
—	—	—	—	100 - 300	80 - 300
—	—	—	—	80 - 500	80 - 500
—	—	—	—	60 - 150	50 - 150
—	—	—	—	100 - 250	100 - 250
25 - 45	—	—	—	—	30 - 40
20 - 40	—	—	20 - 40	—	25 - 35
15 - 25	—	—	20 - 30	—	15 - 25
10 - 20	—	—	—	—	10 - 20
10 - 20	—	—	—	—	10 - 20
—	—	—	—	90 - 140	100 - 140
—	—	—	—	30 - 60	40 - 60
10 - 20	—	—	—	—	—
—	—	—	—	—	—
10 - 20	—	—	—	—	—
10 - 20	—	—	—	—	—



# The easy way to success

## Application recommendations







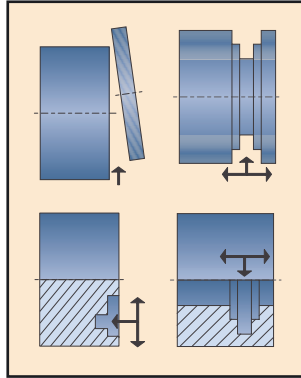

### GX24... standard

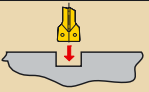
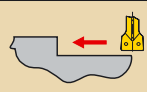





Application:

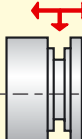

- For all steel materials
- Universal application
- Wide application range
  - parting  $T_{max} = 21\text{mm}$
  - grooving and turning
  - axial grooving
  - internal grooving  $T_{max} = 19\text{mm}$

Type, description	 f [mm/rev.]	 f [mm/rev.]	$a_{max}$ [mm]
GX24-4E6.00N0.50			3,5
GX24-3E5.00N0.40			3
GX24-3E4.00N0.40			3
GX24-2E3.00N0.30			2,5

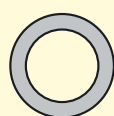
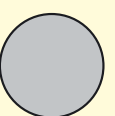
Feed mm/rev.      0   0,1   0,2   0,3   0,4   0,5   0   0,2   0,4   0,6   0,8   1,0

	Parting			Grooving	Grooving and turning
	Tubes	Bars	Difficult conditions		
					
Steel	SR127 / GM40	GM40	—	SR127 / GM40	SR127 / GM40
Stainless	GM40	GM40	—	GM40	GM40
Cast iron	SR127	SR127	—	SR127	SR127
Non ferrous metals	—	—	—	—	—
Heat resistant	—	—	—	—	—
Hard materials	—	—	—	—	—

# The easy way to success

## Application recommendations







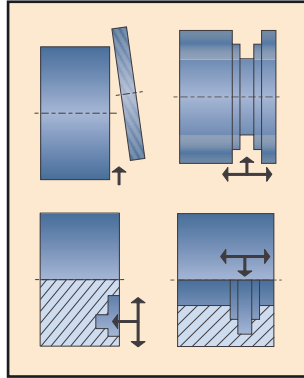



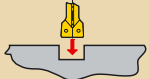
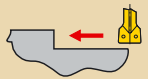



### GX24...-F2



Application:







- For steels in general, particularly suitable for **stainless materials**
- Insert with ground periphery
- Tolerance cutting width  $\pm 0.02$  mm
- Suitable also for parting off tubes and thin-walled materials
- Special profiles possible

Type, description	 f [mm/rev.]	 f [mm/rev.]	 $a_{max}$ [mm]
GX24-4E6.00N0.50-F2			4,0
GX24-3E5.00N0.40-F2			3,5
GX24-3E4.50N0.40-F2			3,0
GX24-3E4.00N0.40-F2			3,0
GX24-2E3.50N0.30-F2			2,5
GX24-2E3.00N0.30-F2			2,5

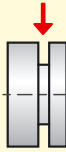
Feed mm/rev.

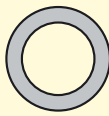
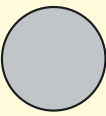
0 0,1 0,2 0,3 0,4 0,5 0 0,2 0,4 0,6 0,8 1,0

	Parting			Grooving	Grooving and turning
	Tubes	Bars	Difficult conditions		
					
Steel	SR735 / GM740	SR735 / GM740	—	SR127 / SR735 GM740	SR735 / GM740
Stainless	GM740	GM740	—	GM740	GM740
Cast iron	SR127	SR127	—	SR127	SR127
Non ferrous metals	—	—	—	—	—
Heat resistant	GM740	—	—	GM740	GM740
Hard materials	—	—	—	—	—



# The easy way to success

## Application recommendations







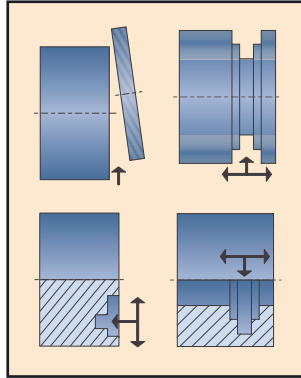



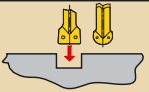
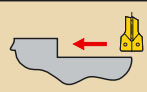



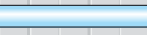

### GX24...-27P





Application:

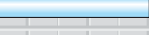

- Particularly suitable for **aluminium and non ferrous metals**
- Insert with highly positive cutting geometry
- Ground periphery
- Tolerance cutting width  $\pm 0,02$  mm
- Extra-smooth rake face through "microfinish"

Type, description	 f [mm/rev.]	 f [mm/rev.]	 $a_{max}$ [mm]
GX24-5R4.00N-27P 			4
GX24-4R3.00N-27P 			3
GX24-4E6.00N0.50-27P			4
GX24-3E5.00N0.40-27P			3,5
GX24-3E4.00N0.40-27P 			3
GX24-2E3.00N0.30-27P			2,5

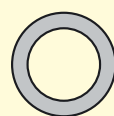
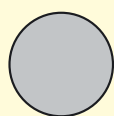
Feed mm/rev.      0 0,1 0,2 0,3 0,4 0,5    0 0,2 0,4 0,6 0,8 1,0

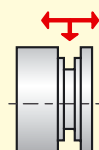
	Parting			Grooving	Grooving and turning
	Tubes 	Bars 	Difficult conditions 		
Steel	—	—	—	—	—
Stainless	—	—	—	—	—
Cast iron	—	—	—	—	—
Non ferrous metals	H216T / TSM20	—	—	H216T / TSM20	H216T / TSM20
Heat resistant	H216T / TSM20	—	—	H216T / TSM20	H216T / TSM20
Hard materials	—	—	—	—	—

# The easy way to success

## Application recommendations







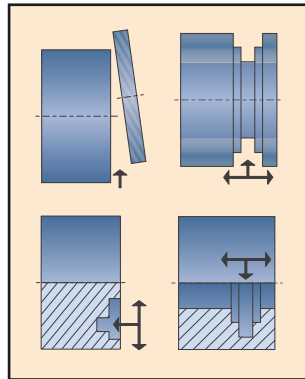

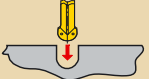

### GX24...-M3



Application:





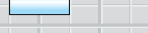

- Inserts for **full radius grooves** and for copy turning
- For all steel materials
- For internal and external machining

Type, description	 f [mm/rev.]	 f [mm/rev.]	 $a_{max}$ [mm]
GX24-4R3.00N-M3			3,5
GX24-3R2.00N-M3			2,5
GX24-3R2.50N-M3			3
GX24-2R1.50N-M3			1,5

Feed mm/rev.

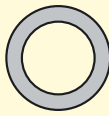
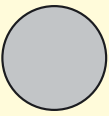
0 0,1 0,2 0,3 0,4 0,5 0 0,2 0,4 0,6 0,8 1,0

	Parting			Grooving	Grooving and turning
	Tubes	Bars	Difficult conditions		
				SR127 / SR735	SR127 / SR735
Steel	—	—	—	SR127 / SR735	SR127 / SR735
Stainless	—	—	—	SR735	SR735
Cast iron	—	—	—	SR127	SR127
Non ferrous metals	—	—	—	—	—
Heat resistant	—	—	—	—	—
Hard materials	—	—	—	—	—



214

[www.ceratizit.com](http://www.ceratizit.com) - just a click.



**Headquarters: CERATIZIT S.A.**

**Main site Luxembourg**

CERATIZIT Luxembourg Sàrl  
Route de Holzem 101, B.P. 51  
L-8201 Mamer

Tel.: +352 312 085-1

Fax: +352 311 911

E-Mail: [info@ceratizit.com](mailto:info@ceratizit.com)

**Main site Austria**

CERATIZIT Austria Gesellschaft m.b.H.

A-6600 Reutte/Tyrol

Tel.: +43 (5672) 200-0

Fax: +43 (5672) 200-502

E-Mail: [info.austria@ceratizit.com](mailto:info.austria@ceratizit.com)



We reserve the right to make technical changes for improvement of the product.

hard material matters

214 EN 02.07  
7000758