

MMIC Balun RF Transformer

MTX2-73+

50Ω 2000 to 7000 MHz

The Big Deal

- Wideband, 2000 to 7000 MHz
- Low insertion loss, 0.6 dB to 6000 MHz
- Low unbalance, 0.8 dB, 4°
- Power handling up to +34 dBm



CASE STYLE: DQ1225

Product Overview

Mini-Circuits MTX2-73+ is a wideband MMIC balun transformer with an impedance ratio of 2:1 covering a wide range of applications from 2000 to 7000 MHz. Fabricated using IPD process technology, this model provides outstanding repeatability with low insertion loss, low amplitude unbalance, low phase unbalance, and RF input power handling up to +34 dBm (2.5W). The unit comes housed in a tiny 3 x 3 x 0.89mm QFN package with low inductance, excellent thermal efficiency, and high ESD rating.

Key Features

Feature	Advantages
Wideband, 2000 to 7000 MHz	MTX2-73+ supports a broad variety of applications including WLAN, WiMAX, WiBRO, ISM, radar and more.
Low insertion loss <ul style="list-style-type: none">• 0.6 dB, 2600 to 6000 MHz• 1.9 dB, 2000 to 7000 MHz	Enables excellent signal power transmission from input to output.
Low unbalance <ul style="list-style-type: none">• 0.8 dB amplitude unbalance• 4° phase unbalance	Low unbalance can improve a system's electromagnetic compatibility by rejecting unwanted common-mode noise.
Tiny size, 3 x 3 x 0.89 mm	Accommodates tight space requirements for dense PCB layouts.

MMIC Balun RF Transformer

MTX2-73+

50Ω 2000 to 7000 MHz

Features

- Wideband, 2000 to 7000 MHz
- Low phase unbalance, 4 deg. and
- Amplitude unbalance, 0.8 dB typ.
- Miniature size, (3 x 3 x 0.89 mm)
- Low cost
- Aqueous washable

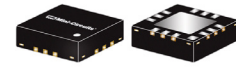

CASE STYLE: DQ1225

Applications

- WLAN
- WiMAX/WiBRO
- ISM
- RADAR

+RoHS Compliant

The +Suffix identifies RoHS Compliance. See our web site for RoHS Compliance methodologies and qualifications

Electrical Specifications at 25°C

Parameter	Frequency (MHz)	Min.	Typ.	Max.	Unit
Impedance Ratio (secondary / primary)			2		
Frequency Range		2000		7000	MHz
Insertion Loss ¹	2600 - 6000	—	0.6	1.0	dB
	2000 - 7000	—	1.9	2.3	
Amplitude Unbalance	2600 - 6000	—	0.5	0.9	dB
	2000 - 7000	—	0.8	1.2	
Phase Unbalance	2600 - 6000	—	3	5	Degree
	2000 - 7000	—	4	7	

1. Insertion loss is referenced to mid-band loss, 1.5 dB.

2. Relative to 180°

Maximum Ratings

Parameter	Ratings
Operating Temperature	-40°C to 85°C
Storage Temperature	-65°C to 150°C
Input RF Power	34 dBm at 25°C

Permanent damage may occur if any of these limits are exceeded.

Pad Connections

Function	Pad Number
PRIMARY DOT (Unbalanced)	2
SECONDARY DOT (Balanced)	9
SECONDARY (Balanced)	7
EXTERNAL GND	1,3,6,8 & paddle
NO CONNECTION	all other

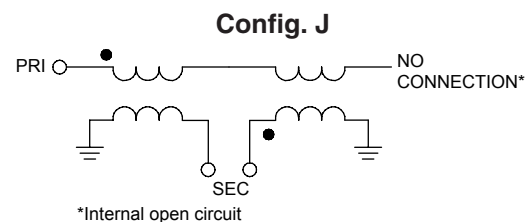

ESD rating

Human body model (HBM): Class 1B (500 to <1000V) in accordance with ANSI/ESD 5.1-2007



Outline Drawing

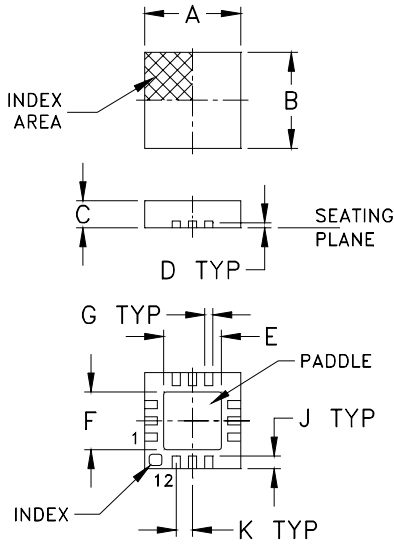

Product Marking



PCB Land Pattern

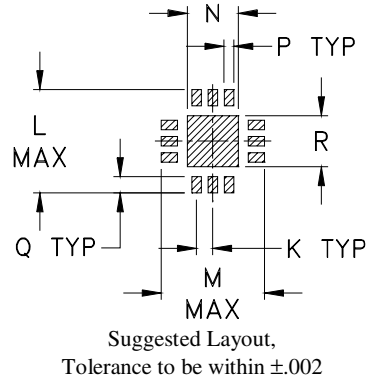

Outline Dimensions (inch/mm)

A	B	C	D	E	F	G	H	J
.118	.118	.035	.008	.057	.057	.009	---	.016
3.00	3.00	0.89	0.20	1.45	1.45	0.23	---	0.41
K	L	M	N	P	Q	R		wt
.020	.127	.127	.049	.010	.020	.049		grams
0.51	3.23	3.23	1.24	0.25	0.51	1.24		0.02

Demo Board MCL P/N: TB-453-MTX273+
Suggested PCB Layout (PL-482)

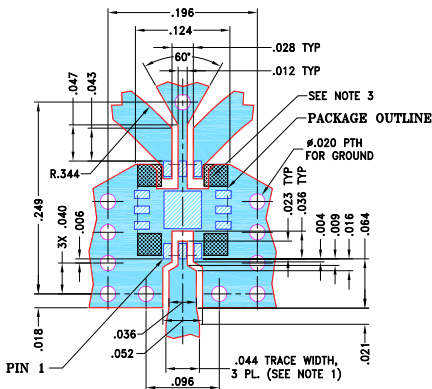

NOTES:

- TRACE WIDTH IS SHOWN FOR ROGERS R04350B WITH DIELECTRIC THICKNESS .020" ± .0015"; COPPER: 1/2 OZ. EACH SIDE. FOR OTHER MATERIALS TRACE WIDTH AND GAP MAY NEED TO BE MODIFIED.
- BOTTOM SIDE OF THE PCB IS CONTINUOUS GROUND PLANE.
- SIGNAL TRACES ARE NOT ALLOWED INSIDE HATCHED AREAS (APPROX. .030 X .030) AT 4 PLACES AS SHOWN.

- DENOTES PCB COPPER LAYOUT WITH SMOBC (SOLDER MASK OVER BARE COPPER)
- DENOTES COPPER LAND PATTERN FREE OF SOLDER MASK

Tape and Reel (F66)

DEVICE ORIENTATION IN T&R

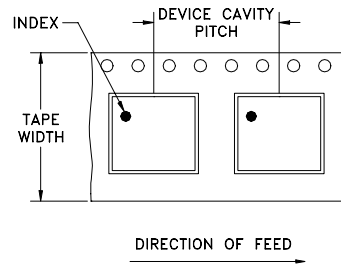

Tape Width, mm	Device Cavity Pitch, mm	Reel Size, inches	Devices per Reel see note
8	4	7	Small quantity standard
			Standard
			20
			50
			100
			200
			500
			1000, 2000

Typical Performance Data

Frequency (MHz)	Insertion Loss (dB)	Input R. Loss (dB)	Amplitude Unbalance (dB)	Phase Unbalance (deg.)
2000	3.37	6.39	0.57	2.66
2600	2.09	13.51	0.38	0.94
3000	1.83	17.37	0.29	0.22
3500	1.77	14.05	0.23	0.53
4000	1.75	12.32	0.26	0.93
4500	1.65	13.39	0.33	0.75
5000	1.55	17.21	0.39	0.18
5800	1.66	20.66	0.43	1.10
6400	2.05	13.30	0.53	1.47
7000	2.68	9.80	0.76	2.30

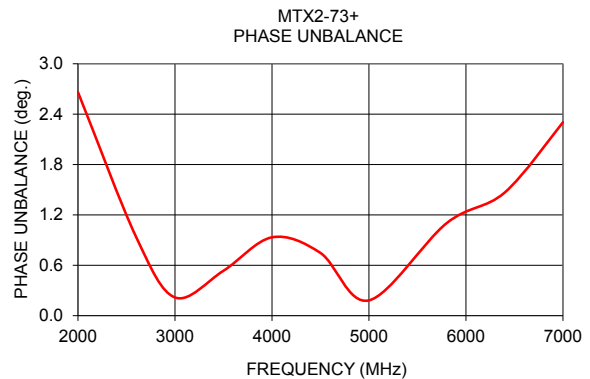
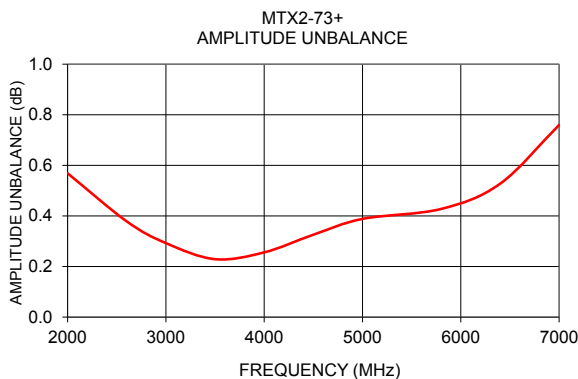
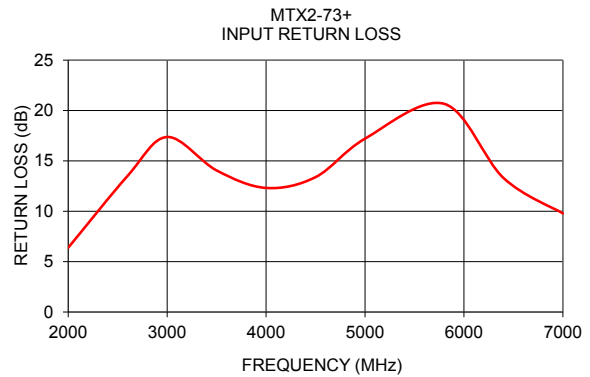
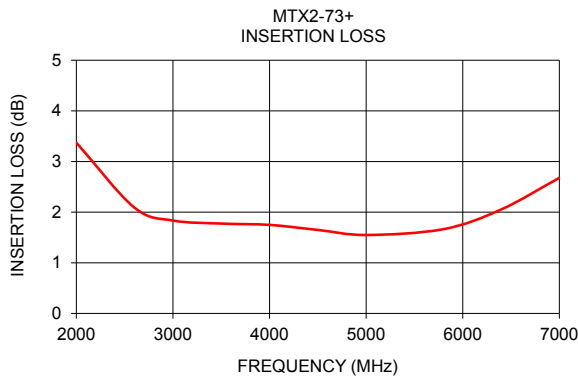

Additional Notes

- A. Performance and quality attributes and conditions not expressly stated in this specification document are intended to be excluded and do not form a part of this specification document.
- B. Electrical specifications and performance data contained in this specification document are based on Mini-Circuit's applicable established test performance criteria and measurement instructions.
- C. The parts covered by this specification document are subject to Mini-Circuits standard limited warranty and terms and conditions (collectively, "Standard Terms"); Purchasers of this part are entitled to the rights and benefits contained therein. For a full statement of the Standard Terms and the exclusive rights and remedies thereunder, please visit Mini-Circuits' website at www.minicircuits.com/MCLStore/terms.jsp

