

FIFE P/N	MANUFACTURER	MANUFACTURER P/N	REMARKS	L	X
29L85627001	ELECTROCRAFT	DPP24T-40-004Z		6.60 [167.6]	9.0 [229]
	AMETEK	2233-MT3384			
29L85627002	ELECTROCRAFT	DPP24T-50-003Z		7.45 [189.2]	9.0 [229]
	AMETEK	2234-MT3418			
29L85627003	AMETEK	2233-MT3384	SEE NOTE (3.)	6.60 [167.6]	9.0 [229]
29L85627004	ELECTROCRAFT	DPP24T-40-010Z		6.60 [167.6]	19.7 [500]
29L85627005	ELECTROCRAFT	DPP24T-50-009Z		7.38 [187.5]	19.7 [500]

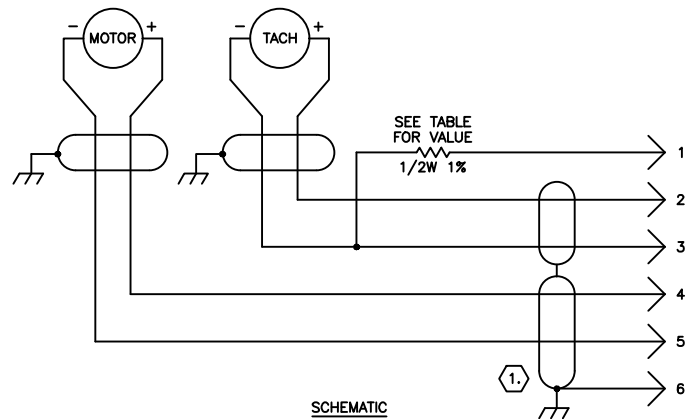

- NOTES:
- CLAMP CABLE SHIELDS TO CONNECTOR STRAIN RELIEF.
 - ROTATION: WITH POSITIVE VOLTAGE APPLIED TO PIN 4, ROTATION SHALL BE CLOCKWISE AS VIEWED FROM OUTPUT SHAFT END AND THE TACHOMETER OUTPUT VOLTAGE SHALL BE POSITIVE ON PIN 2.
 - P/N -003 CAN BE MADE FROM P/N -001 BY REPLACING 14.0K OHM RESISTOR WITH 6.81K OHM RESISTOR (P/N 22402-281).
 - BRUSH LIFE TEST: 5000 HOURS LIFE TEST BASED ON MOTOR RUNNING AT 3100 RPM FOR 85627-002 RPM AND DRAWING 2.0 AMPS FOR 85627-002 CONTINUOUS CURRENT AND ONCE A DAY IN EACH DIRECTION CHANGE.
 - CURRENT TEST (AMPS): CURRENT DRAW AT COMPLETED ASSEMBLY TO BE AT 20V, NOT TO EXCEED 0.20 AMPS.
 - MOTOR TO BE 'CE' COMPLIANT.
 - MOTOR TO BE 'RoHS' COMPLIANT.
 - LABEL I.D. SHALL CONSIST OF:
 - MAXCESS PART NUMBER
 - DESCRIPTION
 - 'CE' AND 'RoHS' CERTIFICATION
 - COUNTRY OF ORIGIN
 - SERIAL NUMBER OF MOTOR
 - REF. 45604 AND 220651 FOR BRUSH PART NUMBERS.

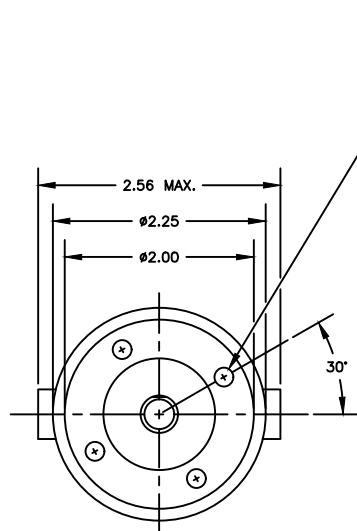

M5 X 0.8 X 0.47 [12mm] DEEP THD HOLES EQUALLY SPACED AS SHOWN ON 1.575 [40mm] DIA BOLT CIRCLE (DEPTH IS MAXIMUM PERMISSABLE SCREW PENETRATION)

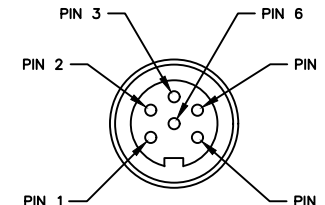
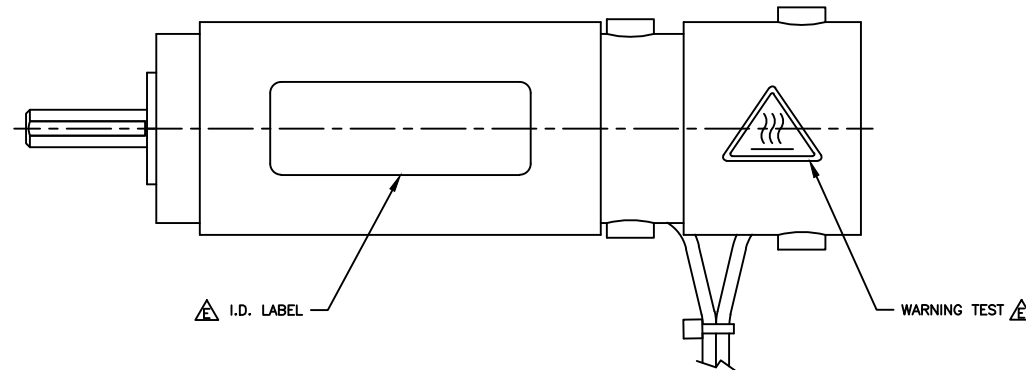
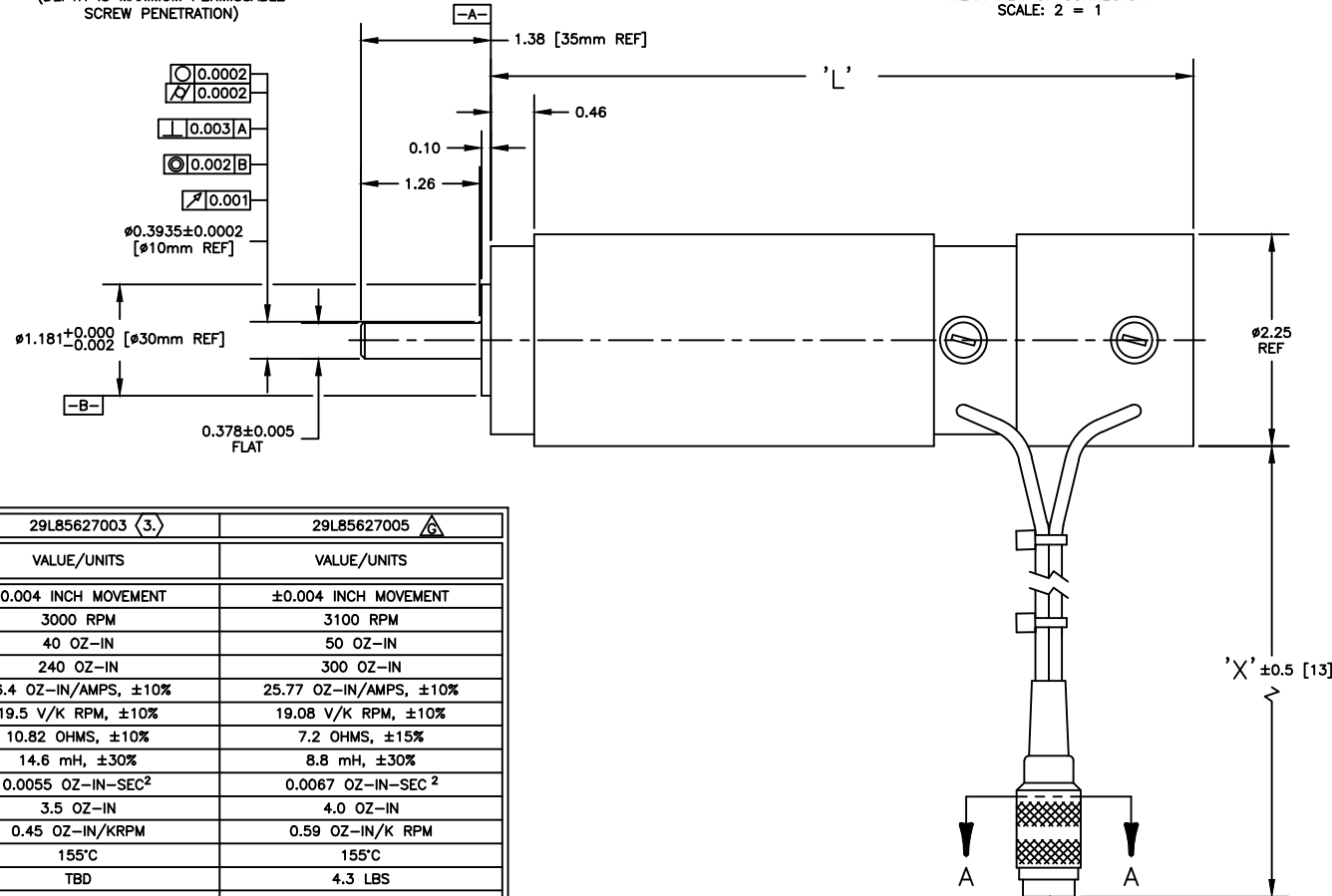

SECTION A-A
REAR VIEW OF CONNECTOR
SCALE: 2 = 1

FIFE P/N	29L85627001/29L85627004	29L85627002	29L85627003 (3.)	29L85627005
MOTOR PARAMETERS @ 25°C	VALUE/UNITS	VALUE/UNITS	VALUE/UNITS	VALUE/UNITS
AXIAL PLAY WITH 10 LB REVERSING LOAD APPLIED	±0.004 INCH MOVEMENT	±0.004 INCH MOVEMENT	±0.004 INCH MOVEMENT	±0.004 INCH MOVEMENT
MAXIMUM OPERATING SPEED	3100 RPM	3100 RPM	3100 RPM	3100 RPM
MAXIMUM CONTINUOUS TORQUE	40 OZ-IN	50 OZ-IN	40 OZ-IN	50 OZ-IN
MAXIMUM PEAK TORQUE	240 OZ-IN	300 OZ-IN	240 OZ-IN	300 OZ-IN
TORQUE SENSITIVITY	26.4 OZ-IN/AMPS, ±10%	25.77 OZ-IN/AMPS, ±10%	26.4 OZ-IN/AMPS, ±10%	25.77 OZ-IN/AMPS, ±10%
BACK EMF CONSTANT	19.5 V/K RPM, ±10%	19.08 V/K RPM, ±10%	19.5 V/K RPM, ±10%	19.08 V/K RPM, ±10%
DC RESISTANCE	10.82 OHMS, ±10%	5.62 OHMS, ±10%	10.82 OHMS, ±10%	7.2 OHMS, ±15%
INDUCTANCE	14.6 mH, ±30%	8.8 mH, ±30%	14.6 mH, ±30%	8.8 mH, ±30%
NOMINAL MOTOR INERTIA	0.0055 OZ-IN-SEC ²	0.0067 OZ-IN-SEC ²	0.0055 OZ-IN-SEC ²	0.0067 OZ-IN-SEC ²
NOMINAL FRICTION TORQUE	3.5 OZ-IN	4.0 OZ-IN	3.5 OZ-IN	4.0 OZ-IN
NOMINAL DAMPING TORQUE	0.45 OZ-IN/KRPM	0.69 OZ-IN/KRPM	0.45 OZ-IN/KRPM	0.59 OZ-IN/KRPM
MAXIMUM WINDING TEMPERATURE	155°C	155°C	155°C	155°C
NOMINAL WEIGHT	TBD	TBD	TBD	4.3 LBS
MINIMUM ADMISSIBLE CONTINUOUS CURRENT IN STANDSTILL	1.3 AMPS	2.0 AMPS	1.3 AMPS	2.0 AMPS
TACHOMETER PARAMETERS @ 25°C	VALUE/UNITS	VALUE/UNITS	VALUE/UNITS	VALUE/UNITS
VOLTAGE SENSITIVITY	3.44 V/1000 RPM, ±10%	3.44 V/1000 RPM, ±10%	3.44 V/1000 RPM, ±10%	3.44 V/1000 RPM, ±10%
MAXIMUM VOLTAGE RIPPLE @ 11 CY/REV	2% AVG-PK	2% AVG-PK	2% AVG-PK	2% AVG-PK
DC RESISTANCE	21.7 OHMS, ±10%	19.35 OHMS, ±10%	21.7 OHMS, ±10%	75 OHMS, ±10%
NOMINAL LOAD RESISTANCE	10K OHMS	10K OHMS	10K OHMS	10K OHMS
INDUCTANCE	0.36 Mh, ±30%	0.43 Mh, ±30%	0.36 Mh, ±30%	0.36 Mh, ±30%
MISCELLANEOUS	VALUE/UNITS	VALUE/UNITS	VALUE/UNITS	VALUE/UNITS
RESISTOR VALUE (SEE SCHEMATIC)	14.0K OHMS	24.9K OHMS	6.81K OHMS (3.)	24.9K OHMS

6-PIN CIRCULAR DIN CONNECTOR WITH GOLD PLATED CONTACTS BINDER P/N 09-0021-92-06 AMPHENOL P/N 703-91T-3400-028 AMPHENOL-TUCHEL P/N T-3400-028

SERVO MOTOR		85626
DRAWING REFERENCE	NUMBER	
UNLESS OTHERWISE SPECIFIED:	TOLERANCES:	
INCHES	MM	
±.1	±.25	
±.03	±.8	
±.010	±.2	
FRACTIONS = STOCK SIZE		
SURFACE FINISH		
EXPOSED	MACHINED	LOCATION
250 AA	125 AA	
STANDARD SHOP PRACTICES AND STANDARD SHOP RUN TOLERANCES PER DRAWING 40400		
DE-BURR ALL EDGES 0.020 (0.5) MAX	OK	
SCALE	SIZE	LOCATION
FULL	D	

BY	DATE	BY	DATE	APVD
DRW				
RWW	10/26/94			
CHECKED				
CR	10/31/94			
APPROVED				
HLW	10/31/94			
REVISION				
SYM		BY	DATE	APVD
H	VENDOR AMETEK WAS QMC TECHNOLOGIES, INC. UPDATED ALL P/N's TO EPICOR STDS. ADDED NOTE 9. ECR #87065	TD	10/26/18	JMP
G	ADDED P/N 85627-005 ECR #78788	JGR	12/19/12	PO
F	ADDED P/N 85627-004 TABBLED MOTOR CABLE LENGTH, 'X' ECR #78702	PO	11/08/12	JMP
E	ADDED ELECTROCRAFT TO 85627-001 ADDED ELECTROCRAFT TO 85627-002 ADDED MOTOR DETAIL VIEW ADDED I.D. LABEL AND WARNING TEST LABEL ADDED NOTES 4 THRU 8 ECR #78501	JGR	09/05/12	JGH
D	ADDED NOTE 3 ECR #59158	KP	04/05/00	MW
C	ADDED P/N -003 ECR #58262	MW	12/28/99	KIH
B	CHGD SUPPLIER FROM ELECTRO CRAFT TO QMC CHNGD DIMS/SPECS TO MATCH QMC ECR #49204	TIGER	09/08/97	OLSON
A	WIRE TO CONNECTOR PIN #2 WAS BLUE GROUND WIRE ON MOTOR WAS GREEN ECR #46567	JC	06/03/96	CR
~	PRODUCTION RELEASE REVISED MOTOR TO CURRENT SPECS	JC	09/12/95	CR
PC	REVISED PER NEW SPECIFICATIONS.	RWW	12/07/94	CR
PB	REVISED PER NEW SPECIFICATIONS.	RWW	11/03/94	CR
PA	PROTOTYPE RELEASE	RWW	10/27/94	CR

222 WEST MEMORIAL ROAD
OKLAHOMA CITY, OK 73114
TEL: 405.755.1600
FAX: 405.755.8425
WWW.MAXCESSINTL.COM

MAXCESS

TITLE
FIFE
SERVO MOTOR
WITH INTEGRAL TACHOMETER
AND 10mm X 35mm LONG SHAFT

DRAWING NO. 85627
SHEET NO. 1 OF 1
REV H